

Dry Bulk Handling Equipment

Dry Bulk Tee.....	37
Aerators.....	37
Solimar Fluidizer Plates.....	37
Drum 450 Series Blower.....	38
Drum 807 and 907 Blowers.....	38
Morris Dry Bulk Clamps.....	39
White Dry Bulk Clamp Gasket.....	39
Victaulic Clamps With Handles.....	39
Miscellaneous Seals and Parts for Dry Bulk Domes.....	39
Heat Plugs.....	39
Valve Flange.....	40
Check Valves.....	40-41
In-line Sight glass.....	41
Butterfly Valve.....	41-42
Butler Aluminum Manhole.....	43
Solimar Hopper Cones.....	43
Solimar Easy Out Hopper Access Door.....	43
Solimar Filter Systems.....	43
Solimar Swing Away Trailer Bottom.....	44
Bellseng Pressure Lock Manhole Cover	45

Aluminum Dry Bulk Tee

Cast lightweight aluminum, one piece casting, groove x groove x flange design, and dimensionally interchangeable with industry standard offerings. **Other sizes available upon request.**



Part#	Size
DRYT444	4"x 4"x 4"
DRYT544	5"x 4"x 4"
DRYT644	6"x 4"x 4"

Heil 1 & 3 Port Aerator

Heil aerators mount in the hopper of dry bulk trailers and use air flow and vibration to eliminate clogging and to speed up unloading time. **For parts breakout see Appendix A-1.**



Part#	Description
DRYAH1	Heil 1 Port Aerator
DRYAH3	Heil 3 Port Aerator
DRYHHS	Heil Hopper Seal
DRYHAG	Heil Aerator Gasket
DRYCONEH	Heil Blue Cone

Sure Seal 1 & 3 Port Aerators

The SureFlo system has increased efficiencies of 20% to 50% over that of some competitors. *SureFlo aerators are interchangeable with Solimar, Heil, Polar, and Fruehauf aerators.* **See Appendix A-2 for a full parts breakout.**



Part#	Description
DRYA101	Sure Seal 1 Port Aerator
DRYA103	Sure Seal 3 Port Aerator
DRYA105	Gray Housing
DRYA108	Gasket
DRYA110	Wing Nut
DRYCONESS	Blue Cone

Drop Bottom Tee and Parts

Cast lightweight aluminum, one piece casting, groove x groove x flange design, and dimensionally interchangeable with industry standard offerings and easy to use swing out bottom drop. **Other sizes available upon request. See Appendix O-1 for parts breakout.**



Part#	Description
DRYBOLT	9"x 5/8"-11 Bolt
DRYT644DB	6"x 4"x 4" Aluminum Drop Bottom Tee
DRYT666DB	6"x 6"x 6" Aluminum Drop Bottom Tee
DRYDOORDBT6	Door Assembly for 6" D/B Tee
DRYDOORDBT8	Door Assembly for 8" D/B Tee
DRYWDBT	5/8"-11 Wing Nut
DRYG6DBT	Gasket for 6" D/B Tee
DRYG8DBT	Gasket for 8" D/B Tee

Sollmar 1 & 3 Port Assembly

Sollmar's disk fluidizer system provides aeration and vibration for fast, efficient unloading of dry bulk materials.



See Appendix A-3 & A4 for parts breakout.

Part#	Description
DRYS111141	Sollmar 1 Port Assembly
DRYS111161	Sollmar 3 Port Assembly
DRYS4124	Blue Cone
DRYS4125	Gray Stem
DRYS4126B	Stainless Steel Hopper Saver
DRYS4127	Blue Disc
DRYS4129	Stainless Steel Tee Handle
DRYS4621	1 Port Clear Manifold
DRYS4623	3 Port Clear Manifold

Sollmar Fluidizer Plates

Fluidizer plates replace fabric pads and aerator plates used in Fruehauf and other bulk trailers. Installed in the trailer hopper plenum, the plate provides far superior unloading performance compared to fabric pads - faster unloading and better cleanout all with less mess. **Please refer to Appendix A-5 thru A-6 for a full parts breakout.**



**Faster Unloading
Less Maintenance
Longer Life
Better Clean-out
No Plugged Lines**



CEMENT / SAND / FLYASH / PEBBLE / LIME / PLASTICS / FLOUR

For a complete list of replacement parts and parts breakout, please refer to **Appendix N-7 thru N-9**.

Drum 450 Series Dry Bulk Truck Drum Blower

High Performance Blower Package for Dry Bulk Discharge

Simple design for easy field maintenance.

325 CFM up to 25 psi (HPD 450), 29 psi (XHPD 450)

Features and Benefits:

Low noise pollution: Low rotor speed and internal compression provide a smoother air stream.

Compact design: Allows direct PTO mount and easy installation. Dual rotation: Allows any 6 or 8 bolt PTO installation.

Plated components: Nickel Chrome plated rotor and PTFE coated side plates for corrosion free operation.

Minimal maintenance: Grease packed roller bearings. 100% oil free air: Special carbon vanes which automatically adjust for wear giving continuous full performance.

Low horsepower: Efficient design allows use of 6-bolt PTO.

Cooler Truck Blower: Allows for greater machine life and extends hot hose life on the trailer.

Quick Strip Design: For easy service in the field.

DRUM 807 and 907 Blowers

DRUM has designed the most versatile blower available today that will off load or vacuum load any product you can carry

Twin Drive Shaft allows for either direction of rotation and correct alignment of drive shaft upon installation.

Oil Lubrication both ends, reduce bearing temperatures and no greasing required.

Diamond Port Design greatly reduces noise and smoothes out airflow.

Computer Designed Ribbing on body, end plates, and gear cases.

Drum Blowers Geared for Higher Efficiency

Cooler running; more efficient rotor profile.

Higher pressure; shorter rotor; less deflection.

Precision ground, helical gears keyed to shaft providing positive timing and easy maintenance.

Dynamically balanced rotors.

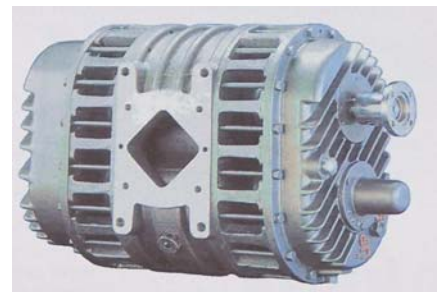

For a complete list of replacement parts and parts breakout, please refer to **Appendix N-1 thru N-6**.

Morris 6" Dry Bulk Clamp

Used for Dry Bulk transfer lines, this T-bolt style clamp is made of steel.

Other sizes also available upon request.



Part#	Description
DRYC6-3C	6" Clamp
DRYC6-3CG	6" Gasket

White Dry Bulk Clamp Gasket

White FDA approved Nitrile gasket for use in dry bulk line clamps.



Part#	Size
DRYGW3	3"
DRYGW4	4"
DRYGW5	5"
DRYGW6	6"

Miscellaneous Seals and Parts for Dry Bulk Domes

DBL offers a wide array of dome lid gaskets and related parts. If you do not see what you need please call DBL's parts department for further help in getting the replacement part you need.

Part#	Description
DRY3519	Knappco LM Cover Latch Assembly
GASDOMEBUTDB	Butler Dry Bulk Dome Seal
GASDOMEFRUBK	Fruehauf Black Dome Gasket
GASDOMEFRUWH	Fruehauf White Dome Gasket
GASDOMEKNBKMM	Knappco Black Buna Gasket
GASDOMEKNWHLM	Knappco White Lid Gasket
GASDOMEKNWHMM	Knappco White Buna Gasket
GASDOMESOLI	Solimar Inner Lid Seal
GASDOMESOLO	Solimar Outer Lid Seal

Gardner Denver Fusible Plug

Part# **MISGD8501246**

This plug is used on the CDL 9, 12, and 15 Series blowers. This plug audibly alerts operator when blower is in danger of over heating.



Morris Dry Bulk Clamps

Used for Dry Bulk transfer lines, this T-bolt style clamp is made of steel.

Other sizes also available upon request.



Part#	Description
DRYC3501	3" Clamp
DRYC4501	4" Clamp
DRYC3501G	3" Gasket
DRYC4501G	4" Gasket

Victaulic Clamps with Handle

Aluminum body, lever operated clamp designed for quick removal and installation on dry bulk transfer pipes.

Available styles: groove x groove, groove x pipe, and pipe x pipe.



Part#	Description
DRYCA3GGW	3"
DRYCA4GGW	4"
DRYCA5GGW	5"
DRYCA6GGW	6"

Hell Six Hole Aluminum Valve Flange

Aluminum 6 hole flange designed to attach to tank hopper for mounting discharge valves. **Four sizes kept in stock with other available upon request.**

Part#	Size
DRYFR3	3"
DRYFR4	4"
DRYFR5	5"
DRYFR6	6"

Drum Melt Plug

Shure Melt plug audibly alerts operator and allows continued operation at lower pressure with a consistent release of temperature from each plug.



Hell Six Hole Aluminum Valve Flange

Aluminum 6 hole flange designed to attach to tank hopper for mounting discharge valves. **Four sizes kept in stock with others available upon request.**

Part#	Size
DRYFR3	3"
DRYFR4	4"
DRYFR5	5"
DRYFR6	6"

Dixon Bayco 4" Check Valve Repair Kit

Part# DRY4040RK1

Flapper replacement kit and necessary hardware for 4040RD check valve.

3" Square Aluminum Flange

Part# DRYFS3

Aluminum 4 bolt weld flange designed to mount 3" check valve.



Dixon Bayco 4" TTMA Flanged Check Valve

Part# DRY4040RD

4" swing check valve with white Nitrile disc for use in air or product lines on dry bulk transfer applications.



Dixon Bayco 3" Swing Check Valves

High flow body design, drop in flapper assembly, high temperature white food grade seal, easy maintenance inspection lid, captive springs and shaft to prevent contamination, and stainless steel hardware.

Available in many different styles. For details, please contact DBL.



Dixon Bayco 3" and 4" Swing Check Valves

Cast aluminum and bronze inspection caps. Safety flapper assembly - all flapper assemblies are drilled and pinned and will not come apart. Choice of seals: metal to metal, Buna or Silicon rubber seals. Choice of models with or without spring loaded flapper. Full flow design - flappers swing out of flow path for maximum flow and low resistance. Designs with large caps allow flapper repair/rebuild on unit.

Available in many different styles, call for further details.



3" Round Flange



3" Threaded Ends



3" Squared Flange



4" Round Flanged or Threaded Ends

Dixon Bayco 2" Swing Checks

Aluminum cast, square flanged and threaded models. Self-aligning, molded "white food grade EPDM" rubber flapper assembly (350° Fahrenheit) with externally mounted springs to prevent ingestion of parts. Easy Open (no tools required) inspection cap and full flow performance.



Squared Flange



Female NPT

Dixon Bayco Horizontal Swing Check Valves

Female NPT x Female NPT

A positive seating disc allows flow only in one direction and a screw in cap provides easy access for cleaning. For horizontal or vertical use. Rated to 200PSI WOG. Brass body and disc. Temperature range -20° Fahrenheit to 150° Fahrenheit.



Dixon Bayco In-line Sight Glass

Designed for dry bulk transfer applications. Available in combination of 3" or 4" coupler or adapter ends. Includes aluminum bodies, Buna seals, acrylic sight glass, stainless steel hardware and bronze arm cams where applicable.



Dixon Bayco Butterfly Valves with Nodular Iron Disc

Aluminum body with nodular iron disc. Stem bushings are made of thermal plastic polymer top and bottom. Stem packing is a Buna-N. Nitrile, FDA approved resilient black seat. Handle is high strength 713 alloy aluminum with retrogressive rearing process - stronger than industry standard cast iron handles. Five position, high strength aluminum alloy throttling plate.

Available in 2", 3", 4", 4" TTMA, 5" and 6"

For replacement parts, accessories, and further specs see [Appendix K-6 & K-7](#)



Dixon Bayco Butterfly Valves with Stainless Steel Disc

Aluminum body with stainless steel disc. Stem bushings are made of thermal plastic polymer top and bottom. Stem packing is a Buna-N. Nitrile, FDA approved white seat. Handle is high strength 713 alloy aluminum with retrogressive rearing process - stronger than industry standard cast iron handles. Five position, high strength aluminum alloy throttling plate.

Available in 3", 4", 5" and 6"

For replacement parts, accessories, and further specs see [Appendix K-6 & K-7](#)

Butterfly Valves with 316 Stainless Steel Disc

Aluminum body with stainless steel disc. Stem bushings are made of thermal plastic polymer top and bottom. Stem packing is a Buna-N. Nitrile, FDA approved white seat. Handle is high strength 713 alloy aluminum with retrogressive rearing process - stronger than industry standard cast iron handles. Five position, high strength aluminum alloy throttling plate. Available in 3", 4", 5" and 6"



For replacement parts, accessories, and further specs see [Appendix K-6 & K-7](#)

Handle Assembly for Ultra Flow

Aluminum handle with notched plate and mounting hardware for use on any ultra-flo dry transfer valve.



Part#	Description
DRYH23	2" - 3"
DRYH46	4" - 6"

Milwaukee Valve With Handle Part# DRYV4MV

With a cast iron body this valve is used for many dry bulk line applications. Available in other sizes upon request. Available in sizes 2" thru 12".



Sure Seal Valve With Handle Part# DRY890-3

Butterfly type valve designed for use in air or product lines. Standard with steel handle. Available in sizes 2" thru 12".





Butler Aluminum Manhole

Butler style 6-cam manhole for dry bulk applications. **DBL offers all assemblies and spare parts for this series of manholes. Please refer to Appendix C-1 for a full breakdown of replacement parts.**

Sollmar Hopper Cones

Aluminum hopper cones for dry bulk trailer applications. Whether you are looking for bolt-on, or weld on (26"/45° only) applications, DBL offers a variety of sizes to fit your needs.

Available Hopper Cones

- 26" ID / 45° SLOPE
- 30" ID / 38° SLOPE
- ALUMINUM
- WELD ON
- BOLT ON



Sollmar Easy Out Hopper Access Door

Access door allows easy hopper interior inspection or install Sollmar aerators without getting inside the product compartment. Stainless steel construction makes Sollmar's E-Z Out Access Door ideal for food, chemicals, and plastics.

Molded on food grade gasket provides low profile for minimum product hang-up. Standard tee-handle makes it easy to tighten or open by hand. Available in two models; flat for square hoppers and curved for conical hoppers.

Sollmar Filter Systems

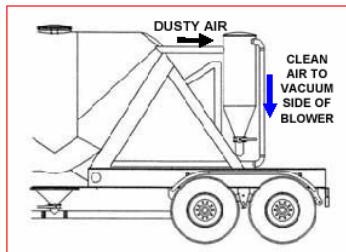

External Canister Filter System

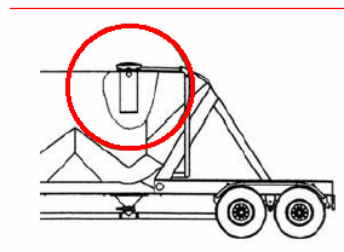

Internal Manway Filter System

Sollmar Filter Systems eliminate product dust by using unique filtering media of engineered porous polymer. Using multiple tubes with up to 1/2 ft.² of filter area, each, provides a large filtering surface in a compact space.

The filter tubes are rated for 50 µ particle size and can be used continuously up to 180° F (82° C). Tubes are fit and gasketed in a machined aluminum mounting plate, which allows for individual inspection and replacement.

Large Filter Area in a Compact Space
Easy Individual Inspection
400 or 900 SCFM – Internal System
600 to 900 SCFM – External System
Longer Life

INTERNAL MOUNT FILTER ASSEMBLIES

Model	Mounting Ring Diameter	Filter Tube Length	Air Flow (SCFM)
6054	20"	24"	400
6055	20"	36"	600
6056	24"	24"	600
6057	24"	36"	900

EXTERNAL MOUNT FILTER ASSEMBLIES

Model	Canister Diameter	Filter Tube Length	Air Flow (SCFM)
6071	20"	36"	600
6070	24"	36"	900

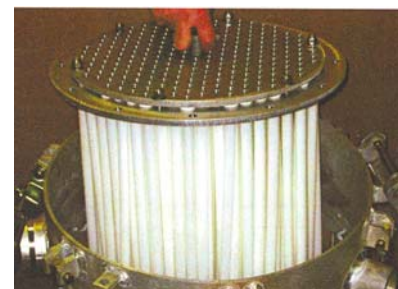

Pneumatic or Gravity Unloading

Two Way Hauling of Different Products

Easy Clean Out

5" or 6" Unloading Pipes

Rugged Design for Long Service

Bolt On or Weld On

Sollmar Swing Away Trailer Bottom

Swing away bottoms offer the best in versatility for customers looking for multipurpose use of their bulk trailer. Swing Away Bottoms permit pneumatic or gravity discharge, allow for easy clean out and washing. Can be used for two-way hauling of different products.

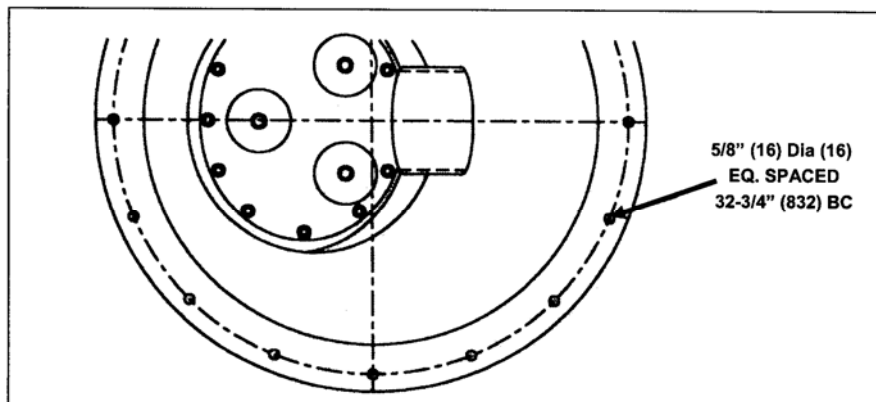
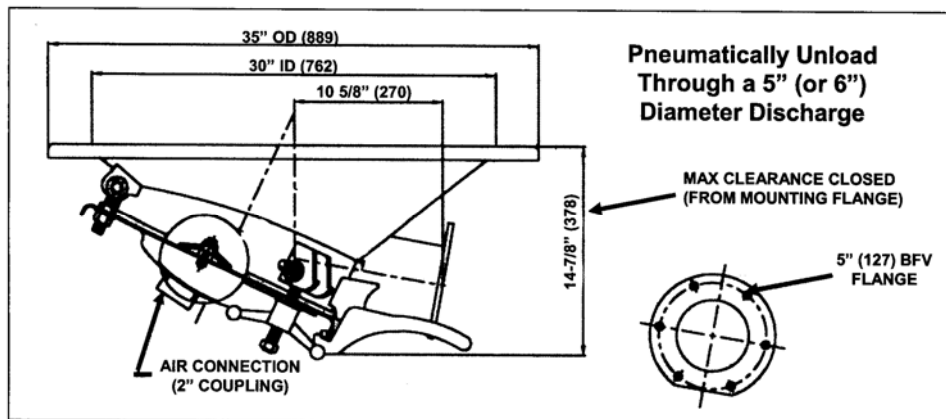
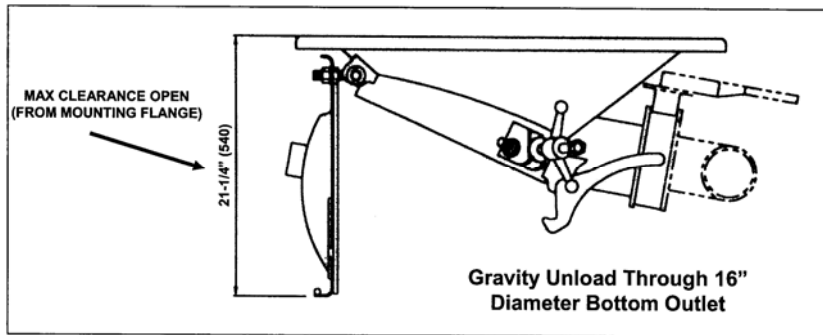
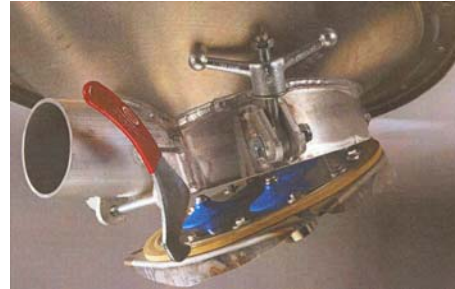

Bellseng Pressure Lock Manhole Cover

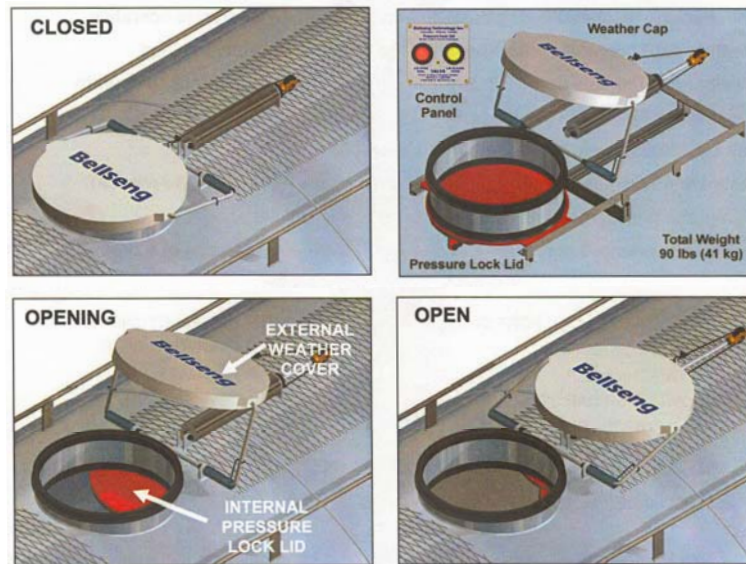

The Bellseng Pressure Lock Manhole Cover is an innovative internal port closure that eliminates the need for drivers to climb on the trailer before loading. The one button operation not only greatly improves driver safety, but equally improves the driver's working conditions and vastly improves rig turnaround time.

For kits and options such-as non-pressurized applications please refer to **Appendix C-3**

Special Orders

DBL can special order items upon request. Many times these include parts on discontinued items or oddball, hard-to-find parts that are not easily found. DBL will do its best to help you and your company find the parts it needs while delivering the quality service that will help keep your business up and running.