

# Pumps

Jabsco 2" and 2-1/2" Pumps.....	195
Viking/Viking, Waukesha 130, Flotech uni-bloc 551, Ranger 11, 17, 22 Series/Roper 3622.....	196
Blackmer ATX Aluminum Series Pump.....	197
Blackmer TXV Series Pump.....	198
Blackmer STX3 Stainless Steel Transport Pump.....	199
Blackmer Transmax Transport Pump Model TX206A.....	200
Blackmer TXD Series Pumps.....	201
Drum SSC150 Pump.....	202
Drum 2000 Liquid Pump.....	202
Drum 2130 Liquid Pump (replacement parts).....	203
Betts Hydraulic Pump.....	204
Betts Sliding Valve Hydraulic Pump .....	204

---

### Jabsco 2" Pump

Jabsco's 2" pump is designed specifically for farm pick-ups that haul milk and are equipped with a remote drive. The pump body and shaft are made of 316 Stainless Steel, the impeller is Neoprene based, the shaft seal is sanitary carbon face, the ports consist of two inch ACME threads and 2" clamp, and the weight is approximately 34 pounds. Below is a sample list of available replacement parts. **To view a full parts breakout refer to the appendix.**

Part#	Description
JAB07866-0000	Collar
JAB08984-0005	Impeller
JAB09023-0000	Seal Assembly
JAB10345-0001	End Plate
JAB10346-0020	Wear Plate
JAB12927-0000	Clamp Frame
JAB18023-0000	Pump Shaft
JAB18024-0000	Clamp Screw
JAB18726-0000	Small Retaining Ring
JAB18753-0007	Bearing/Pier
JAB91701-2830	Large Retaining Ring
JAB92000-0030	O-Ring
JAB92702-0780	Bearing Seal



For a full parts breakout refer to **Appendix F-4**

### Jabsco 2-1/2" 130 GPM Pump

This product is specifically designed for farm pick-up milk tanker trucks. Jabsco pumps are also available as pedestal mounted or close-coupled units with capacities to 100 GPM for other sanitary applications.

**Body:** Type 316 Stainless Steel  
**Impeller:** Jabsco Sanitary Neoprene Compound  
**Seal:** Sanitary Mechanical  
**Bearings:** Ball/Roller Bearings  
**Shaft:** Type 316 Stainless Steel  
**Ports:** 2-1/2" Acme Threads  
**Weight:** 50 lb (23 kg) Approximately



Part#	Description
JAB08500-0005	Impeller
JAB0R137	O-Ring for C. Seal
JAB21908-0001	Clamp Screw
JAB21909-0001	Clamp Frame
JAB22044-2001	Shaft Retaining Ring
JAB22644-6000	Seal Assembly
JAB91700-2870	Small Retaining Ring
JAB91701-4391	Large Retaining
JAB92000-1213	O-Ring
JAB92601-0450	Rear Ball Bearing
JAB92601-0460	Front Bearing
JAB92701-0880	Bearing Seal

For a full parts breakout refer to **Appendix F-5**

**Viking/Johnson Pump**

Replacement parts for stainless steel, food grade, dual lobe pump for transfer of sanitary goods.

For a full parts breakout refer to **Appendix F-1 & F-2**

Part#	Description
<b>VIKB34-2819-06</b>	Relief Valve Diaphragm
<b>VIKZ094-6031-0A</b>	Rotor Shaft O-Ring
<b>VIKZ94-6227-0A</b>	O-Ring
<b>VIKZ94-6236-02</b>	Relief Valve O-Ring
<b>VIKZ94-6270-0A</b>	Pump Cover O-Ring
<b>VIKZ94-6332-0A</b>	O-Ring
<b>VIKZ94-6044-02</b>	O-Ring

Part#	Description
<b>WAU000030009</b>	Pump Grease Seal
<b>WAU000030011</b>	Pump Oil Seal
<b>WAU000030012</b>	Pump Oil Seal
<b>WAU060036000</b>	Pump Front Bearing
<b>WAU060052001</b>	Pump Rotor Jam Nut
<b>WAU105852</b>	Pump Wing Nut
<b>WAU107186</b>	Pump Rear Bearing
<b>WAU107188</b>	Bearing Kit
<b>WAU41013</b>	Plastic Pump Plug
<b>WAUBD0092000</b>	Pump Grease Fitting
<b>WAUN50338</b>	Pump O-Ring
<b>WAUN70131</b>	Pump O-Ring
<b>WAUN70272</b>	Pump Cover O-Ring
<b>WAUN70331</b>	Pump O-Ring
<b>WAUSTD136009</b>	Pump Lock Washer

**Waukesha 130 Pump**

316 stainless steel pump body and cover, with heavy duty 316 shafts. Exclusive, non-galling Waukesha "88" alloy rotors with tighter clearances handle a wider range of viscosities effectively. Pressure capability~200 PSI/13.8 Bar. For more info contact DBL.

For a full parts breakout refer to **Appendix F-3**

**Flowtech Uni-Bloc 551**

3A Sanitary stainless steel food grade pump. Top wing style impellers constructed to handle a wide variety of products.



Part#	Description
<b>FLO4130-N</b>	Rear Oil Seal
<b>FLO4135-N</b>	Front Oil Seal
<b>FLO4232-E</b>	Rotor Bolt O-Ring
<b>FLO4233-E</b>	Rotor Shaft O-Ring
<b>FLO4235-E</b>	Cover O-ring
<b>FLO4238-NQ</b>	Lip Seal Quad Rings
<b>FLO4239-N</b>	Gear Cover O-Ring
<b>FLO5272</b>	Double O-Ring Lip Seal

For a full parts breakout refer to **Appendix F-6 thru F-8**

Part#	Description
<b>ROPD11-332</b>	Gasket
<b>ROPD11-333</b>	Flanged Gasket
<b>ROPD11-338</b>	Oval Case Gasket
<b>ROPD11-90</b>	Flange Gasket
<b>ROPN43-1</b>	Pump Shaft Packing
<b>ROPN43-1GF</b>	Graphite Packing Set

For a full parts breakout refer to **Appendix F-39**

**Ranger 11, 17, 22 Series Pumps, Roper 3622**

Carbon steel construction, gear style pump for use with a wide variety of products. From asphalt to petroleum, this pump can handle your needs.

**Blackmer ATX Aluminum Series Pump**  
**Rotary Vane Pumps For Tank Trucks and Transports**

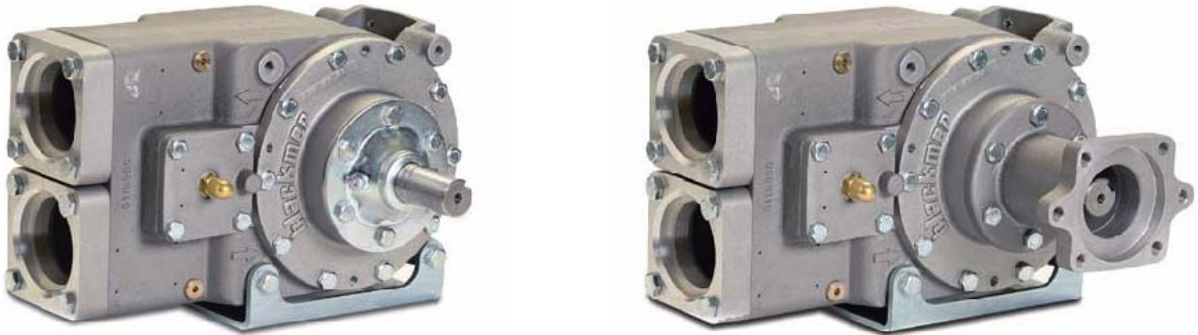

**Design Features**

Weighing 100 lbs. (45 kgs.) the aluminum ATX pump is ideal for light, clean, non-corrosive fluids compatible with aluminum. The light-weight transport pump works on most petroleum applications. Pump construction consists of grease lubricated ball bearings, Blackmer cartridge mechanical seals, Duravanes, hardened steel drive shaft with ductile iron rotor and cast iron liner and end discs.

**Performance Capabilities**

Speeds up to 1,000 rpm  
Delivers up to 300 GPM (1,135 lpm)  
Maximum viscosity of 300 SSU (63 cSt)  
Operating Temperatures of 240°F (115°C)  
Parallel ports for easy piping  
Drain/Gauge Plugs

**Options**

Pipe Flanges: 3" (80 mm) socket  
weld - aluminum or steel  
Three Mounting Bracket Positions  
Pneumatic actuated relief valve assembly  
Hydraulic Drive Option

**Reduced Life Cycle Costs**

The ATX series combines Blackmer's proven sliding vane technology with a replaceable cast iron liner and end discs for maximum pump performance and reduced life cycle costs.

Parts breakout  
**Appendix F-25 thru F-28**

## **Blackmer TXV Series Pump**

High Temperature, Rotary Vane Pumps for Asphalts and Viscous Fluids

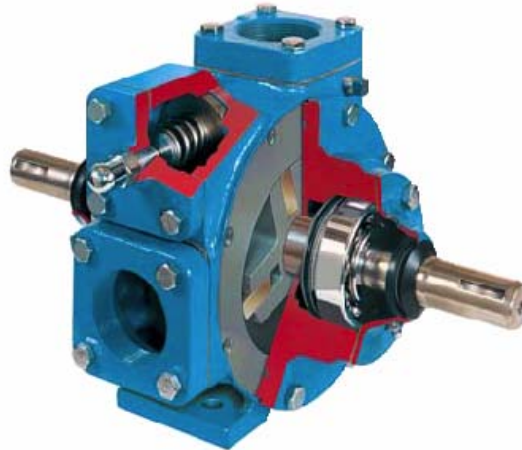

### **Design**

Blackmer TXV pumps provide high volume, low speed transfer of clean fluids compatible with a cast iron construction. For fluids that do not work well with mechanical seals, a TXV pump is the answer. They are well suited for thick, viscous fluids that can solidify when exposed to the air. The TXV pump models are available in 2" and 3" port sizes. Standard construction includes a special open rotor design that offers easy flushing, bronze vanes, FKM elastomers, PTFE lip seals, high temperature grease lubricated ball bearings isolated from the pumpage and high temperature gasket materials. The TXV pump delivers more fluid per revolution than comparably ported gear pumps. And slower operating speeds mean longer service life and reduced maintenance requirements. The TXV's internal relief valve protects the pump from build-up.

### **High Viscosity**

TXV pumps are ideal for handling viscous or shear sensitive fluids. The key to the TXV series' versatility is Blackmer's unique sliding vane rotor design that provides sustained, high level performance over a wide viscosity range. Slow operating speeds and non-pulsating flow minimizes shear and agitation of the fluid. Optional Heating Jackets are available if required.

### **Self-Priming and Dry Run Capability**

TXV pumps are self-priming, and the self-adjusting vanes help maintain this capability. TXV pumps can run dry for short periods of time for priming.

### **Application**

Typical applications for the TXV pumps include: asphalts, greases, lube oils, resins, molasses, bunkered fuels, inks, and adhesives.

Parts breakout  
Appendix F-31 thru F-34

### **How Blackmer's sliding vane action works**

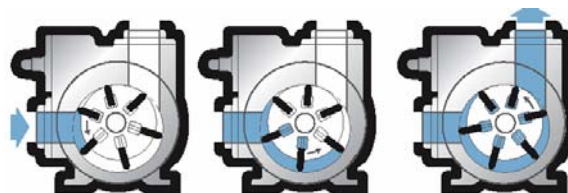

## **Blackmer STX3 Stainless Steel Transport Pump**



### **Stainless Steel Construction**

Blackmer's STX3 is designed to meet a wide range of corrosive and non-corrosive fluids for common carriers. Standard construction: 316 stainless steel with external ball bearings, non-metallic Duravanes, PTFE elastomers, Blackmer chemical mechanical seals. See Typical Applications List.

### **Fast Off-Loading**

The STX3 offers flow rates up to 250 GPM (946 LPM) with differential pressures up to 125 PSI (8.6 bar or 862 kPa) and maximum speed of 800 RPM. A typical 6,000 gallon (22,700 liter) tanker can be off-loaded as quick as 24 minutes.

### **Dry Run Capability**

Blackmer's non-metallic vanes self-compensate for wear and allow the STX3 to run dry for short periods of time for self-priming and blowing lines clean, with-out pump damage.

### **Easy Maintenance**

Internal wear is limited almost completely to the sliding-vanes, which can be replaced with ordinary metric hand tools.

### **Typical Applications**

**Solvents**  
**Chemicals**  
**Chlorides**  
**Sulfates**  
**Vegetable oils**  
**Urea**  
**Many acids**

### **Unique Features**

**316 Stainless Steel**  
**Self-Priming**  
**Line Clearing**  
**Ball Bearing Construction**  
**Chemical Mechanical Seals**  
**Adjustable Relief Valve**  
**Versatile Mounting Bracket**

## Blackmer Transmax Transport Pump Model TX206A



PTO Drive



Hydraulic Drive

### Design

The unique open rotor design makes the Transmax highly versatile. The sliding vane design provides sustained high-performance capabilities including self-priming and line clearing.

### Application

The TX206A is capable of pumping thin to thick liquids from 30 to 50,000 ssu (7 to 10,500 cp) with sustained performance at rated P.T.O. speeds, maximum 800 rpm.

### Benefit

The Transmax is self-priming and capable of line clearing; these benefits are not found with existing gear pumps. Also, the Transmax is specifically designed for easy cleaning. Multiple drain ports allow for proper flushing in a variety of mounting positions.

### Hydraulic Drive Options

Blackmer offers fully-integrated hydraulic drive systems including pumps, motors, close coupled hydraulic motor adapters, control valves, P.T.O.'s and coolers.

### How Blackmer's sliding vane action works

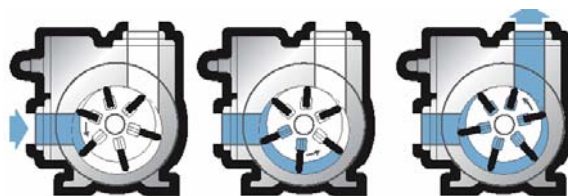

**Also available:**  
**Replacement Parts For Blackmer Transmax Transport Pump Model TX400**  
**Call DBL for more information**

Replacement parts for TX206 and TX400  
**Appendix F-35 thru F-38**

### Blackmer TXD Series Pumps

Part#	Description
BLA031425	Pump Head
BLA041431	Bearing Cover Head
BLA091619	Vanes
BLA121607	Push Rod
BLA221665	Dual Rotor
BLA317815	Grease Fitting
BLA331601	Seal Assembly
BLA331918	Grease Seal
BLA341601	Shaft Cover
BLA381403	Flanged Gasket
BLA383940	Bearing Cover Gasket
BLA531603	Bypass Gasket
BLA651603	2-1/2" X 2" Flange
BLA651611	2-1/2" Flange
BLA701480	Dirt Shield
BLA701947	Head Seal Ring
BLA701992	Grease Relief Fitting
BLA740057	Strainer
BLA740058	T-Strainer
BLA871180	Air Diaphragm Kit
BLA891696	Air Bypass
BLA898951	Pump Kit
BLA903156	Bearing
BLATXD2-1/2AV	Blackmer Pump With Air Bypass

Example of replacement parts. For a full breakdown on different size pumps, please refer to **Appendix F-19 thru F-24**



#### Reliability

Durable pumps for fast and quiet operation. Sliding-vane design provides sustained performance and trouble free operation.

#### Unique Features

Adjustable relief valve protects pump from excessive pressure. Optional air operated diaphragm relief valve offers easy hose and nozzle handling. T-Type strainers are available to protect pumping systems from damage caused by welding slag and foreign matter in the piping and tanks.

#### Sizing Options

Available in 1.5, 2, 2.5, 3, and 4 inch port sizes with flow rates from 10 to 500 U.S. gallons (2 to 113 m<sup>3</sup>/H) and pressures up to 125 PSI (8.6 bar).

#### Applications

Fuel oil delivery truck, fleet refueling, lube oil, aviation refuelers, transports of petro chemical, gasoline, solvents, and many more.



**DRUM SSC150 Liquid Pump**

The SSC150 Chemical Pump is engineered for product transfer of chemical and pharmaceutical products from tank trailers. This pump is specifically designed for applications where corrosion resistance and product cleanliness is important. The quick strip, easy clean design promotes ease of maintenance, and assures contamination free product delivery. The SSC150 is ideal for pumping thin, non-lubricating, abrasive, and thick liquids.

Please refer to **Appendix F-41 thru F-45**



Part#	Description
<b>DRU512161201</b>	Lip Seal Assembly Repair Kit
<b>DRU522030200</b>	Front Cover O-Ring
<b>DRU522020200</b>	Rotor O-Ring
<b>DRU516070249</b>	Shim Set (Arch)
<b>DRU170412250</b>	Stud
<b>DRU518090200</b>	O-Ring (Shim Retainer)
<b>DRU513002202</b>	Sealed Machined Assembly
<b>DRU307058203</b>	Sight Glass

**DRUM 2000 Liquid Pump**

The FP2000 food grade pump is specifically designed for the transfer of liquid food products from tank trailers. The quick strip design and frontloading o-ring seals provide easy cleaning and maintenance. The non-contacting rotors are highly reliable and assure contamination free product delivery with flows up to 232 gallons per minute. The new compact design provides a lighter pump with greater pressure capabilities and long seal life. Improved rotor profile ensures quiet, pulse-less flow and resists cavitations.

Please refer to **Appendix F-9** for parts breakout and replacement parts

Part#	Description
<b>DRU190012200</b>	Front Cover Hex Nut
<b>DRU510001200</b>	Front Bearing
<b>DRU516072229</b>	Shim Kit
<b>DRU522001226</b>	Nitrile O-Ring
<b>DRU522001227</b>	Nitrile O-Ring
<b>DRU522001228</b>	Nitrile O-Ring
<b>DRU526151201</b>	Gear Case Gasket
<b>DRU530051200</b>	Rotor Nut
<b>DRU512010218</b>	Nitrile Oil Seal (Lip)
<b>DRU518080202</b>	Seal
<b>DRU522001205</b>	O-Ring Seal NBR



### DRUM 2130 Liquid Pump

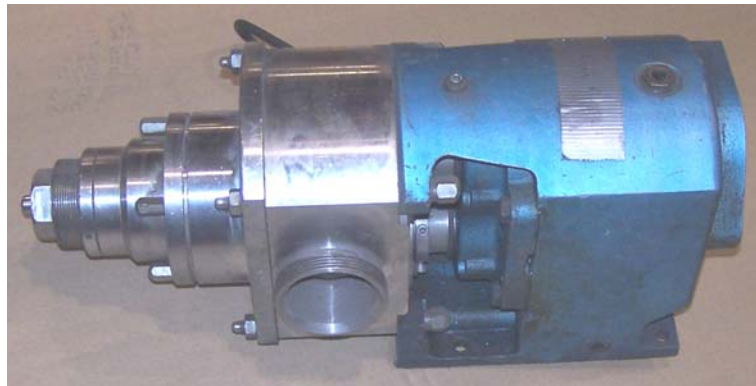

Part#	Description
DRU512050201	Rear Oil Seal (Nitrile)
DRU512050200	Front Oil Seal (Viton)
DRU513000200	Mechanical Seal Assembly-Silicon & Carbide
DRU513002200	Mechanical Seal Assembly-Stainless & Carbide
DRU307058203	Oil Sight Glass with Washer
DRU522000205	Front Cover O-Ring
DRU522000211	Rotor/Shaft O-Ring NBR
DRU522001202	O-Ring
DRU522001203	O-Ring
DRU522001204	O-Ring
DRU522001205	O-Ring
DRU522001209	O-Ring
DRU518061200	Right Hand Rotor Nut with Screw
DRU518061201	Left Hand Rotor Nut with Screw
DRU513043200	Glands/Food (4 Teflon) Non-Lube
DRU513043201	Glands/Food (4 Teflon) Lube
DRU513030203	Seal U Ring 2000 Thrower Ring
DRU518001200	Bearing Strip Retainer
DRU522000210	Rotor Nut O-Ring
DRU510001200	Front Bearing
DRU190012200	Front Cover Hex Nut
DRU170412250	12MM Stud with Clip
DRU510003201	Roller Bearing (Complete)
DRU512010201	Oil Seal/Front Lip Seal (Nitrile)
DRU512010202	Rear Lip Seal
DRU516041203	Sleeve, Double O-Ring (set screws included)
DRU516070222	Shims, Bearing Retainer
DRU516070223	Shim Set (Arch)
DRU513132200	Relief Valve Diaphragm
DRU513090201	O-Ring Seal (Double) Complete

The Drum 2130 has been discontinued but replacement parts are still available. Listed is an example of potential replacement parts. Please call for availability, for some of these parts may be discontinued at anytime.

Please reference **Appendix F-13** for a full parts breakout.

**Betts Hydraulic Pump**  
**Stainless Steel Valve Block and Internal Components**  
**Horizontal or Vertical Mounting**  
**Replaceable Pump Head**  
**Tamper Resistant Pressure Relief**  
**Front and Side Outlet Ports**

The new **Betts Hydraulic Pump HP46982SL** is designed as a corrosion resistant, reliable hydraulic pump for use with any Betts hydraulically operated valve or vent. The pump head and internal parts are made of corrosion resistant stainless steel. The reservoir is made of cast iron with a durable powder coating. The pump head can be replaced without unbolting the reservoir from its mounting.

¼ NPT Hydraulic connections are conveniently located at both the front of the pump and on the right side. A drain plug allows the reservoir to be drained without unbolting the pump. Pump can be mounted horizontally or vertically with outlet end down.

Parts breakout **Appendix F-53**

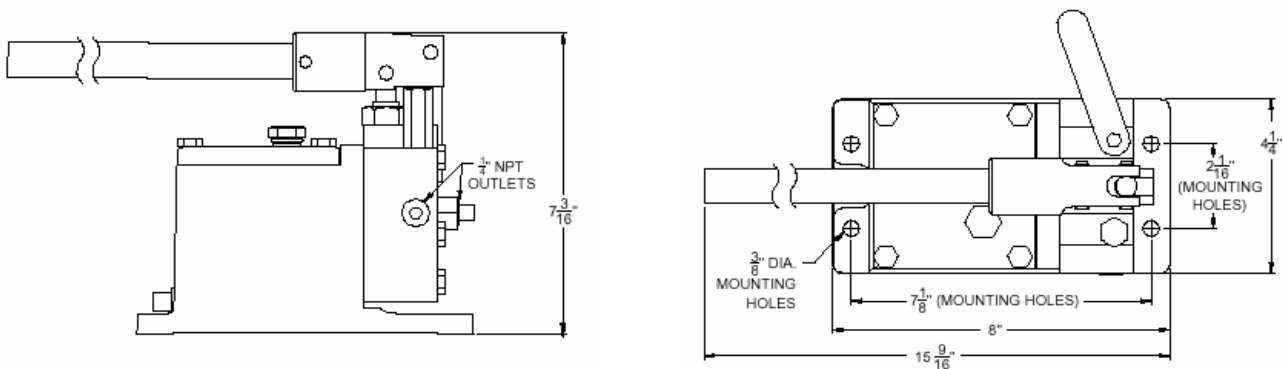

**Betts Sliding Valve Hydraulic Pump**

This hydraulic pump is an integral part of the hydraulic gate valve system. The pump is designed to prevent damage to the valve or hydraulic line from over-pressurization. If the pump is used to operate more than one valve, use **Distributor No. 16283** for individual valve control.

Parts breakout **Appendix F-54**

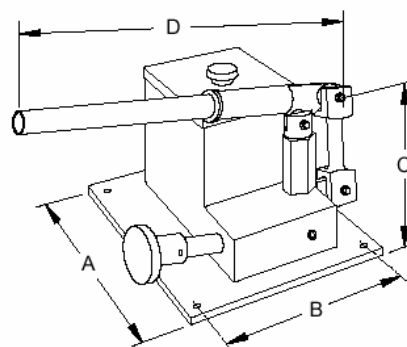

A	B	C	D
8" Sq.	6 5/8	7	14 1/2

## Having Pump Problems?



Whether you need pump parts or the pump needs fixed on your trailer, DBL is your one stop location for all your pump needs to keep your equipment and company up and running.

For more information call DBL today  
**1-877-DBL-TANK**  
or email us  
[dbltank@dbltank.com](mailto:dbltank@dbltank.com)