

Suspensions and Landing Gear

Suspension Breakouts.....	225
Hendrickson Kits and Parts.....	226-227
Inner and Outer Nuts.....	227
Studs.....	227
Reyco Kits and Parts.....	228
Fruehauf Kits and Parts.....	228
Stemco Products.....	228-229
Generic Axle Roller Bearings.....	228
Bearing.....	228
Great Dane Gasket.....	228
Fruehauf Equalizer Bushing Kits.....	229
Landing Gear Cranks.....	229
GD 70 Landing Gear.....	229
Holland Mark V Landing Gear.....	229
Conmet Hubs and Drums.....	230

DBL carries a variety of suspensions, suspension parts, and suspension kits. Below are a few of our most popular suspensions. For a full breakout of these suspensions and others, please refer to the appendix number given for each. If you do not see the suspension you are looking for please call DBL for assistance. For miscellaneous parts, please refer to pages 226 thru 230.

Fruehauf "F" Series Trailer Four Spring Suspension
Appendix H-1

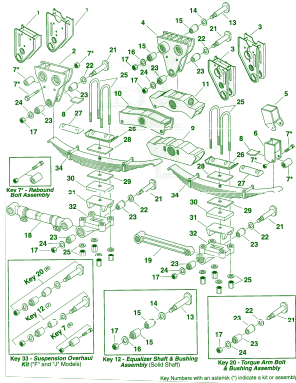

Hendrickson Trailer HK/HS 190/230
HT 190/230/250/300
Appendix H-3

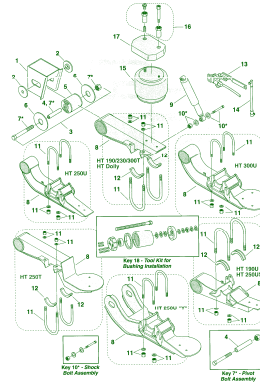

Hendrickson Trailer Intraxx AA230L/250L
Trailer Air Suspension
Appendix H-7

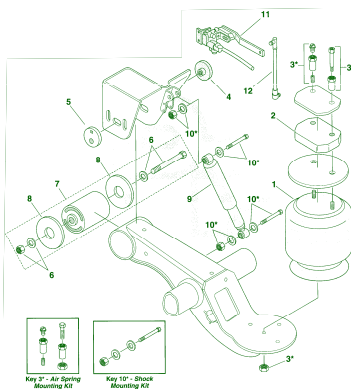

Hendrickson Trailer Intraxx/Vantraxx AA230/250T,
HKA180/200/250 Trailer Air Suspension
Appendix H-9

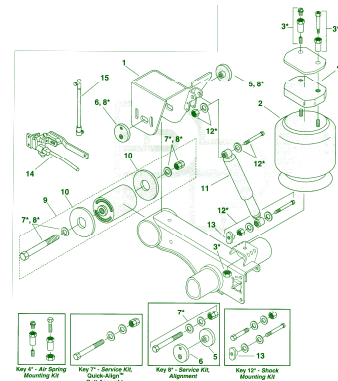

Neway AR90/90-1/92/93/250, ARU92/93
Air Trailer Suspension
Appendix H-11

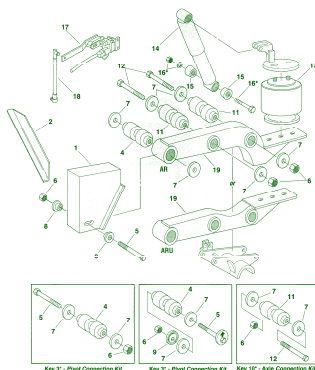

Reyco Model 21B/21B-FAB
Tandem Four Spring Trailer Suspension
Appendix H-13

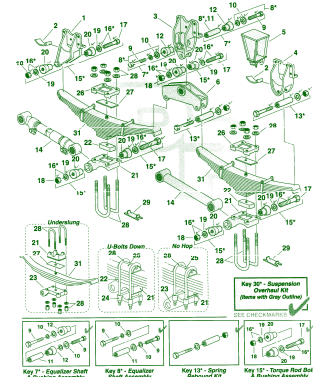

Hendrickson Quik-Align Washers

Washers used in conjunction with Hendrickson Intraxx Suspensions.



Part#	Description
SUSS20925	Eccentric Washer
SUSS20924	Concentric Washer

Hendrickson Quik-Align Kits

Washers used in conjunction with Hendrickson Intraxx Suspensions.



Part#	Description
SUSS24679	Pivot Bolt Kit
SUSS24691	Bushing Kit

Hendrickson Old Style Weld On Kits

Alignment kits used in conjunction with HT Series suspensions.



Part#	Description
SUSS2770	Weld On Alignment Washer
SUSS3646	Pivot Bolt Kit
SUSS6914	Bushing Kit

Hendrickson Air Bag Kits

Air bag kits used in conjunction with Hendrickson Air Ride Systems. Kits also available for other model suspensions.



Part#	Description
SUSS22630	Use with 1-1/8" spacer
SUSS22631	Use with 1-7/8" spacer
SUSS22632	Use with 3-1/8" Plastic Spacer

Hendrickson Air Bags



Part#	For Hendrickson Model
SUSS20010	HT230
SUSS21784	AA250, HKA250
SUSS21800	AA230

Hendrickson Shock Absorber

See Hendrickson breakouts in Appendix H-3 thru H-10 for more shock absorber information.

DBL also carries other shock absorbers, please call for further details.



3/4" -16 Headed Studs

PART NO	A	B	C	D	E
13-1104R/L	2-7/8"	9/16"	1/2"	1-1/2"	1-13/16"
13-1110R/L	3-7/8"	9/16"	1/2"	2-1/2"	2-13/16"

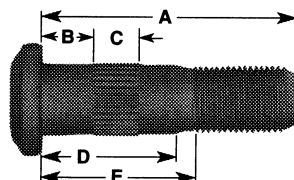

3/4" -16 Studs With Lugs

PART NO	A	B	C
13-2323R/L	3-3/8"	1-13/32"	1-11/16"

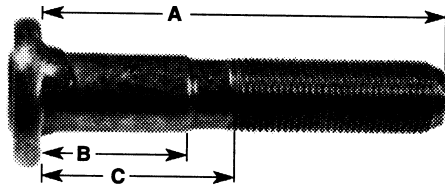

3/4" - 16 Inner Nuts

Part# ACS13-3005R (Right)
Part# ACS13-3005L (Left)

For stud piloted wheels.



3/4" -16 Inner Nut

Part# ACS13-3026R (Right)
Part# ACS13-3026L (Left)

For stud piloted wheels.



1-1/8" -16 Outer Nut

For stud piloted wheels.



Flanged Nut For 8 Hole Wheel
Part# ACSR005991

Flanged nut for 8 hole hub piloted wheel.



Flanged Nut For 10 Hole Wheel
Part# ACSR006000

Flanged nut for 10 hole hub piloted wheel.

Hendrickson Bolt Kit



Part#	Description
SUSS24021	Shock Repair Kits
SUSUBK3R14	3" Full Radius U-Bolt Set, 14" Long
SUSUBK3R16	3" Full Radius U-Bolt Set, 16" Long

Hendrickson AK-147 Air Ride Leveling Kit



Part#	Description
SUSS23460	3 Way Pilot Valve
SUSS24680	Protection Valve
SUSAK-147	Dump Valve

Reyco Transpro Spring Suspension Parts

Torque arm and bushings for service of Transpro suspension.



Part#	Description
SUS0075-20	19-7/8" Torque Arm Assembly
SUS1035-20	Adjustable Torque Arm Assembly
SUS0022-01K	Bushing Kit

Fruehauf Bushing Kits

All necessary hardware to re-bush the Fruehauf F-2 Suspension.



Part#	Description
SUS334-565	Radius Rod Bushing Kit
SUSUXA000011-900	Torque Arm Bushing Kit

Fruehauf Adjustable Torque Arm

Torque arm and bushings for service of Fruehauf suspension.

Part#	Description
SUSUCF002640001	Adjustable Torque Arm
SUSUCF002640004	Adjustable Torque Arm

Generic Axle Roller Bearings

Part# **SUSBEARING**

Stocking a complete line of TN and TP style axle bearings.



Reyco 21B Spring Suspension Parts

Torque arm and bushings for service of 21B suspension.



Part#	Description
SUS15172-1	16-1/4" Adjustable Torque Assembly
SUS15173-1	18-7/8" Adjustable Torque Arm
SUS15178-1	16-1/4" Torque Arm
SUS15179-1	18-7/8" Torque Arm

Reyco 21B Torque Arm Bushing Kit

Part# **SUSUCF002640001**

All necessary hardware to re-bush the Reyco 21B Suspension.



Stemco Products

Stocking a complete line of high quality Stemco axle and hub products.



Part#	Description
SUS300-4009	Stemco Cap
SUS11-0670	Pro-Par Clear Hub Cap
SUS11-0680	Dayton O-Ring
SUS330-3009	Stemco Hub Gasket
SUS330-3067	Stemco Gasket
SUS330-3118	Large Diameter Hub Gasket
SUS340-4195	Stemco Cap
SUS359-5995	Stemco Window Kit

Stemco Seals

Stocking a complete line of Stemco Wheel Seals.



Part#	Description
SUS372-7097	
SUS372-7098	
SUS372-7099	

Fruehauf Equalizer Bushing Kit

Part# SUSUXA000004-900

All necessary hardware to re-bush the Fruehauf F-2 Equalizer.



Reyco 21B Equalizer Bushing Kit

Part# SUSTK18998

All necessary hardware to re-bush the Reyco 21B equalizer kit.



Landing Gear Cranks

Mild steel landing gear crank handles for both vertical and horizontal applications.



Part#	Description
MISLGC15H	15" Horizontal
MISLGC15V	15" Vertical
MISLGC21H	21" Horizontal
MISLGC21V	21" Vertical

GD70 Landing Gear

Lifting capacity of 70,000 lbs. at 100ft.-lbs. Input torque, ultimate load capacity of 170,000 lbs., and side load capacity of 29,000lbs. Four models available, varying in retracted and extended lengths. Please refer to Appendix H-23 for replacement parts breakout.

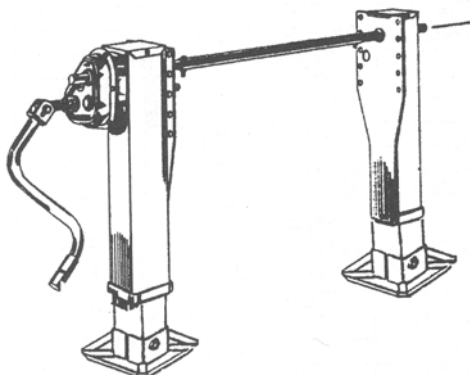

Holland Mark V Landing Gear

Lifting capacity of 62,500 lbs. at 100ft.-lbs. Input torque, ultimate load capacity of 200,000 lbs., and side load capacity of 32,000lbs. The Mark V exceeds all AAR M-931 and all TTMA RP-4 performance specifications. For replacement parts refer to Appendix H-24

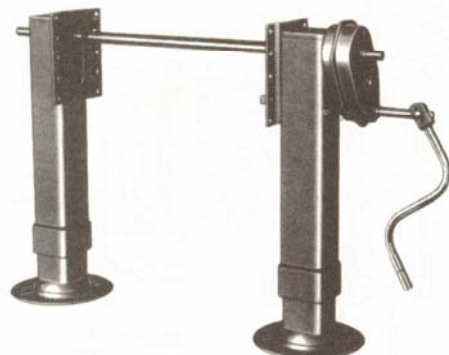



ConMet Hubs

PreSet Aluminum and Ductile Iron Hubs

Aluminum Hubs

PreSet hub assemblies utilize pre-adjusted bearings to simplify installation, improve seal and bearing life and reduce maintenance requirements. This results in improved overall vehicle performance and lower life cycle cost.

ConMet aluminum hubs enable trucks and trailers to reduce weight, maximize payload, and increase profits. Their lightweight aluminum hubs are available for virtually all axle and wheel configurations for medium and heavy-duty vehicle applications.

When ordering make sure to specify 8 or 10 stud, hub piloted or stud piloted, and inner and outer bearing numbers.

ConMet Drums

TruTurn Brake Drum

CastLite Brake Drum

Cast Brake Drum

ConMet Brake Drums offer robust and reliable braking solutions for a wide range of heavy-duty vehicle applications. Every ConMet brake drum design is certified to meet Federal Motor Vehicle Safety Standard testing requirements. ConMet's superior design capabilities are utilized to develop the most durable brake drums available on the road today for heavy-duty truck and trailer applications.

When ordering drums make sure to specify 8 or 10 stud, hub piloted or stud piloted, and width of shoe (standard is usually 7" and a mountain shoe 8-1/2")



Whether it be stainless steel, aluminum, carbon steel, air or spring ride suspensions; DBL Tank Services can fabricate and install any suspension with unparalleled flexibility

Call DBL today for further information
1-877-DBL-TANK

